

# Fire-resistance test on fire collars protecting a concrete floor slab penetrated by services

## Test Report

**Author:** Chris Wojcik  
**Report number:** FSP 1857

**Date:** 19 March 2018

**Client:** Combat Collars Pty Ltd

Commercial-in-confidence



**Inquiries should be address to:**

Fire Testing and Assessments	Author	The Client
NATA Registered Laboratory	Infrastructure Technologies	Combat Collars Pty Ltd
14 Julius Avenue	14 Julius Avenue	17 Glenn Street,
North Ryde, NSW 2113	North Ryde, NSW 2113	Dean Park NSW 2761
Telephone +61 2 9490 5444	Telephone +61 2 9490 5500	Telephone +61 0410 662 549

**Report Status and Revision History:**

VERSION	STATUS	DATE	DISTRIBUTION	ISSUE NUMBER
Revision A	Draft for review	01/02/2018	CSIRO	FSP 1857
Revision B	Final For Issue	08/03/2018	CSIRO and The Client	FSP 1857
Revision C	Amend	19/03/2018	CSIRO and The Client	FSP 1857

**Report Authorization:**

AUTHOR	REVIEWED BY	AUTHORISED BY
Chris Wojcik	Brett Roddy	Brett Roddy
		
19 <sup>th</sup> March 2018	19 <sup>th</sup> March 2018	19 <sup>th</sup> March 2018

## Use of this Report

### **Use of Reports – Testing**

*This report is subject to binding obligations under which it was prepared. In particular, the Report must not be used:*

- *as a means of endorsement; or*
- *in a company prospectus or notification to a Stock Exchange document for capital raising, without the prior written consent of CSIRO.*

*The Report may be published verbatim and in full, provided that a statement is included on the publication that it is a copy of the Report issued by CSIRO.*

*Excerpts of the Report may not be published.*

### **Use of Reports – Consultancy**

*This report is subject to binding obligations under which it was prepared. In particular, the Report may only be used for the following purposes:*

- *the information in the Report may be used by the party that commissioned the Report for its internal business operations (but not licensing to third parties);*
- *the report may be copied for distribution within the organisation that commissioned the Report;*
- *copies of the Report (or extracts of the Report) may be distributed to contractors and agents of the organisation that commissioned the Report who have a need for the Report for its internal business operations. Any extracts of the Report distributed for this purpose must clearly note that the extract is part of a larger Report held by the organisation that commissioned the Report and which has been prepared by CSIRO.*

*The name, trade mark or logo of the CSIRO must not be used without the prior written consent of CSIRO.*

*The Report must not be used as a means of endorsement without the prior written consent of CSIRO.*

## Copyright and disclaimer

© 2017 CSIRO To the extent permitted by law, all rights are reserved and no part of this publication covered by copyright may be reproduced or copied in any form or by any means except with the written permission of CSIRO.

## Important disclaimer

CSIRO advises that the information contained in this publication comprises general statements based on scientific research. The reader is advised and needs to be aware that such information may be incomplete or unable to be used in any specific situation. No reliance or actions must therefore be made on that information without seeking prior expert professional, scientific and technical advice. To the extent permitted by law, CSIRO (including its employees and consultants) excludes all liability to any person for any consequences, including but not limited to all losses, damages, costs, expenses and any other compensation, arising directly or indirectly from using this publication (in part or in whole) and any information or material contained in it.

# Contents

1	Introduction .....	5
1.1	Identification of specimen .....	5
1.2	Sponsor .....	5
1.3	Manufacturer .....	5
1.4	Test standard .....	5
1.5	Reference standard.....	5
1.6	Test number.....	5
1.7	Test date .....	6
2	Description of specimen .....	6
2.1	General.....	6
2.2	Dimensions .....	8
2.3	Orientation.....	8
2.4	Conditioning.....	8
3	Documentation .....	8
4	Equipment.....	8
4.1	Furnace .....	8
4.2	Temperature .....	9
4.3	Measurement system .....	9
5	Ambient temperature .....	9
6	Departure from standard .....	9
7	Termination of test .....	9
8	Test results .....	10
8.1	Critical observations .....	10
8.2	Furnace temperature.....	10
8.3	Furnace severity.....	10
8.4	Specimen temperature .....	10
8.5	Performance .....	11
9	Fire-resistance level (FRL) .....	12
10	Field of direct application of test results .....	12
11	Tested by .....	12
	Appendices .....	13
	Appendix A – Measurement location .....	13
	Appendix B – Photographs .....	14
	Appendix C – Furnace Temperature .....	18
	Appendix D – Installation drawings.....	25
	Appendix E – Specimen Drawings .....	30
	Appendix F – Certificate(s) .....	33
	References .....	38

# Fire-resistance test on fire collars protecting a concrete floor slab penetrated by services

## Sponsored Investigation No. FSP 1857

### 1 Introduction

#### 1.1 Identification of specimen

The sponsor identified the specimen as five (5) cast-in Fire Collars protecting a 120-mm thick concrete floor slab penetrated by five (5) PVC pipes.

#### 1.2 Sponsor

Combat Collars Pty Ltd  
17 Glenn Street,  
Dean Park NSW 2761

#### 1.3 Manufacturer

Combat Collars Pty Ltd  
17 Glenn Street,  
Dean Park NSW 2761

#### 1.4 Test standard

Australian Standard 1530, Methods for fire tests on building materials, components and structures, Part 4-2014, Fire-resistance tests of elements of construction.

#### 1.5 Reference standard

Australian Standard 4072, Components for the protection of openings in fire-resistant separating elements, Part 1 - 2005, Service penetrations and control joints.

#### 1.6 Test number

CSIRO Reference test number: FS 4714/4088

## 1.7 Test date

The fire-resistance test was conducted on 17 October 2017.

# 2 Description of specimen

## 2.1 General

The specimen comprised an 1150-mm x 1150-mm x 120-mm thick reinforced concrete slab penetrated by five (5) Iplex PVC stack pipes protected by cast-in Combat Collars fire collars.

The pipes used in the test are stated to be manufactured in accordance with:

- AS/NZS 1260 - PVC-U pipes and fittings for drain, waste and vent application

For the purpose of the test, the specimens were referenced as Penetrations 1, 2, 3, 4, and 5. Documents containing a complete description of each specimen were supplied by the sponsor and are retained on file.

Penetration 1 – Combat Clean 100 (CC-100) cast-in collar protecting a nominal 100-mm Iplex Polyvinyl Chloride (PVC-SC) stack pipe incorporating a coupling inside the collar

The Combat Clean 100 collar comprised a plastic casing with a 110-mm inner diameter, a 210-mm external diameter base flange, and 0.75-mm thick steel base plate. The 80-mm high collar casing incorporated a layer of 443-mm x 48-mm x 12-mm thick intumescent material, as shown in drawing titled Combat Clean 100 CC-100 provided by Combat Collars Pty Ltd.

The penetrating service comprised a 110-mm outer diameter PVC-SC pipe with a wall thickness of 3.6-mm fitted through the collar, with a coupling located in the collar's sleeve, for a total wall thickness of 6.6-mm through the collar's sleeve. The pipe projected vertically, 2000-mm above the concrete slab and approximately 500-mm into the furnace chamber. The pipe was supported at nominally 500-mm and 1500-mm from the unexposed face of the slab by two support clamps spaced apart at nominally 1000-mm. The pipe was open at the unexposed end and capped on the exposed end with an 100-mm PVC pipe cap.

Penetration 2 – Combat Clean 40 (CC-40) cast-in collar protecting a nominal 40-mm Polyvinyl Chloride (PVC) stack pipe

The Combat Clean 40 collar comprised a plastic casing with a 43-mm inner diameter, a 151-mm external diameter base flange, and 0.75-mm thick steel base plate. The 79-mm high collar casing incorporated a layer of 265-mm x 38-mm x 8-mm thick intumescent material, as shown in drawing titled Combat Clean 40 CC-40 provided by Combat Collars Pty Ltd.

The penetrating service comprised a 43-mm outer diameter PVC pipe with a wall thickness of 2-mm fitted through the collar. The pipe projected vertically, 2000-mm above the concrete slab and approximately 500-mm into the furnace chamber. The pipe was supported at nominally 500-mm and 1500-mm from the unexposed face of the slab by two support clamps spaced apart at nominally 1000-mm. The pipe was open at the unexposed end and capped on the exposed end with an 40-mm PVC pipe cap.

### Penetration 3 – Combat Clean 50 (CC-50) cast-in collar protecting a nominal 50-mm Iplex Polyvinyl Chloride (PVC) stack pipe

The Combat Clean 50 collar comprised a plastic casing with a 56-mm inner diameter, a 151-mm external diameter base flange, and 0.75-mm thick steel base plate. The 79-mm high collar casing incorporated a layer of 265-mm x 38-mm x 8-mm thick intumescent material, as shown in drawing titled Combat Clean 50 CC-50 by Combat Collars Pty Ltd.

The penetrating service comprised a 56-mm outer diameter PVC pipe with a wall thickness of 2.3-mm fitted through the collar. The pipe projected vertically, 2000-mm above the concrete slab and approximately 500-mm into the furnace chamber. The pipe was supported at nominally 500-mm and 1500-mm from the unexposed face of the slab by two support clamps spaced apart at nominally 1000-mm. The pipe was open at the unexposed end and capped on the exposed end with an 56-mm PVC pipe cap.

### Penetration 4 – Combat Clean 50 (CC-50) cast-in collar protecting a nominal 50-mm Iplex Polyvinyl Chloride (PVC) stack pipe incorporating a fitting inside the collar

The Combat Clean 50 collar comprised a plastic casing with a 56-mm inner diameter, a 151-mm external diameter base flange, and 0.75-mm thick steel base plate. The 79-mm high collar casing incorporated a layer of 265-mm x 38-mm x 8-mm thick intumescent material, as shown in drawing titled Combat Clean 50 CC-50 by Combat Collars Pty Ltd.

The penetrating service comprised a 56-mm outer diameter PVC pipe with a wall thickness of 2.3-mm fitted through the collar, with a coupling located in the collar's sleeve, for a total wall thickness of 4.6-mm through the collar's sleeve. The pipe projected vertically, 2000-mm above the concrete slab and approximately 500-mm into the furnace chamber. The pipe was supported at nominally 500-mm and 1500-mm from the unexposed face of the slab by two support clamps spaced apart at nominally 1000-mm. The pipe was open at the unexposed end and capped on the exposed end with an 56-mm PVC pipe cap.

### Penetration 5 – Combat Clean 100 (CC-100) cast-in collar protecting a nominal 100-mm Iplex Polyvinyl Chloride (PVC-SC) stack pipe

The Combat Clean 100 collar comprised a plastic casing with a 110-mm inner diameter, a 210-mm external diameter base flange, and 0.75-mm thick steel base plate. The 80-mm high collar casing incorporated a layer of 443-mm x 48-mm x 12-mm thick intumescent material, as shown in drawing titled Combat Clean 100 CC-100 provided by Combat Collars Pty Ltd.

The penetrating service comprised a 110-mm outer diameter PVC-SC pipe with a wall thickness of 3.3-mm fitted through the collar. The pipe projected vertically, 2000-mm above the concrete slab and approximately 500-mm into the furnace chamber. The pipe was supported at nominally 500-mm and 1500-mm from the unexposed face of the slab by two support clamps spaced apart at nominally 1000-mm. The pipe was open at the unexposed end and capped on the exposed end with an 110-mm PVC pipe cap.

## 2.2 Dimensions

The overall dimension of the concrete slab was 1150-mm wide x 1150-mm long x 120-mm thick, to suit the opening in the specimen containing frame.

## 2.3 Orientation

The reinforced concrete slab was placed horizontally on top of the furnace chamber, and subjected to fire exposure from the underside.

## 2.4 Conditioning

The concrete slab was left to cure for a period longer than 30 days.

# 3 Documentation

The following documents were supplied or referenced by the sponsor as a complete description of the specimen and should be read in conjunction with this report:

Drawing titled Combat Clean 40 CC-40, undated, provided by Combat Collars Pty Ltd.

Drawing titled Combat Clean 50 CC-50, undated, provided by Combat Collars Pty Ltd.

Drawing titled Combat Clean 100 CC-100, undated, provided by Combat Collars Pty Ltd.

Drawing numbered Penetration # 1 – 100 PVC-SC Pipe + Fitting – Stack – Combat Clean 100, dated 28 November 2017, provided by Combat Collars Pty Ltd.

Drawing numbered Penetration # 2 – 40 PVC Pipe – Stack – Combat Clean 40, dated 28 November 2017, provided by Combat Collars Pty Ltd.

Drawing numbered Penetration # 3 – 50 PVC Pipe – Stack – Combat Clean 50, dated 28 November 2017, provided by Combat Collars Pty Ltd.

Drawing numbered Penetration # 4 – 50 PVC Pipe – Stack – Combat Clean 50, dated 28 November 2017, provided by Combat Collars Pty Ltd.

Drawing numbered Penetration # 5 – 100 PVC-SC Pipe – Stack – Combat Clean 100, dated 28 November 2017, provided by Combat Collars Pty Ltd.

# 4 Equipment

## 4.1 Furnace

The furnace had a nominal opening of 1000-mm x 1000-mm for attachment of vertical or horizontal specimens.

The furnace was lined with refractory bricks and materials with the thermal properties as specified in AS 1530.4-2014 and was heated by combustion of a mixture of natural gas and air.



## 4.2 Temperature

The temperature in the furnace chamber was measured by four type K, 3-mm diameter, and 310 stainless steel Mineral Insulated Metal Sheathed (MIMS) thermocouples. Each thermocouple was housed in high-nickel steel tubes opened at the exposed end.

The temperatures of the specimen were measured by glass-fibre insulated and sheathed K-type thermocouples with a wire diameter of 0.5-mm.

Location of the thermocouples on the unexposed face of the specimen are described in Appendix A.

## 4.3 Measurement system

The primary measurement system comprised a multiple-channel data logger, scanning at one minute intervals during the test.

# 5 Ambient temperature

The temperature of the test area was 22°C at the commencement of the test.

# 6 Departure from standard

There were no departures from the requirements of AS 1530.4-2014.

# 7 Termination of test

The test was terminated at 241 minutes by the agreement with the sponsor.

## 8 Test results

### 8.1 Critical observations

The following observations were made during the fire-resistance test:

<b>Time</b>	<b>Observation</b>
40 seconds -	Smoke is being emitted from the unexposed end of Penetration # 1 pipe.
1 minute, 40 seconds -	Smoke is being emitted from the unexposed end of Penetration # 5 pipe.
1 minute, 45 seconds -	Smoke from Penetration # 1 pipe has stopped.
2 minutes -	Smoke is being emitted from end of Penetration # 2, # 3, # 4, and # 5 pipes.
3 minutes -	The lower half of Penetration # 1 pipe is distorting and collapsing onto the support bracket. Smoke from Penetration # 5 pipe has stopped.
4 minutes -	Penetration # 5 pipe has distorted and partially slipped through the support bracket.
6 minutes -	Smoke from Penetration # 5 pipe has stopped.
9 minutes -	Smoke from Penetration # 2 and # 4 pipes has reduced. Penetration # 4 pipe has distorted near the base.
16 minutes -	Smoke is being emitted from the base of Penetration # 1. Fluid is appearing at the grout/slab junctions of the penetrations.
19 minutes -	Smoke from Penetration # 1, # 2, # 3, and # 4 pipes has stopped. Slight smoke from Penetration # 5 pipe.
16 minutes -	Smoke is being emitted from the base of Penetration # 1. Fluid is appearing at the grout/slab junctions of the penetrations.
55 minutes -	Fluid is bubbling at the grout/slab junctions of the penetrations.
207 minutes -	Maximum temperature rise failure on Penetration # 1 – On grout 25-mm from the pipe.
228 minutes -	Maximum temperature rise failure on Penetration # 5 on grout 25-mm from pipe.
241 minutes -	Test terminated.

### 8.2 Furnace temperature

Figure 1 shows the standard curves of temperature versus time for heating the furnace chamber and the actual curves of average and maximum temperature versus time recorded during the heating period.

### 8.3 Furnace severity

Figure 2 shows the curve of furnace severity versus time during the heating period.

### 8.4 Specimen temperature

Figure 3 shows the curve of maximum temperature versus time associated with Penetration 1.

Figure 4 shows the curve of maximum temperature versus time associated with Penetration 2.

Figure 5 shows the curve of maximum temperature versus time associated with Penetration 3.

Figure 6 shows the curve of maximum temperature versus time associated with Penetration 4.

Figure 7 shows the curve of maximum temperature versus time associated with Penetration 5.

## 8.5 Performance

Performance observed in respect of the following AS 1530.4-2014 criteria:

Penetration 1 – Combat Clean 100 (CC-100) cast-in collar protecting a nominal 100-mm Iplex Polyvinyl Chloride (PVC-SC) stack pipe incorporating a coupling inside the collar

Structural adequacy - not applicable

Integrity - No failure at 241 minutes

Insulation - 207 minutes

Penetration 2 – Combat Clean 40 (CC-40) cast-in collar protecting a nominal 40-mm Iplex Polyvinyl Chloride (PVC) stack pipe

Structural adequacy - not applicable

Integrity - No failure at 241 minutes

Insulation - No failure at 241 minutes

Penetration 3 – Combat Clean 50 (CC-50) cast-in collar protecting a nominal 56-mm Iplex Polyvinyl Chloride (PVC) stack pipe

Structural adequacy - not applicable

Integrity - No failure at 241 minutes

Insulation - No failure at 241 minutes

Penetration 4 – Combat Clean 50 (CC-50) cast-in collar protecting a nominal 50-mm Iplex Polyvinyl Chloride (PVC) stack pipe incorporating a fitting inside the collar

Structural adequacy - not applicable

Integrity - No failure at 241 minutes

Insulation - No failure at 241 minutes

Penetration 5 – Combat Clean 100 (CC-100) cast-in collar protecting a nominal 100-mm Iplex Polyvinyl Chloride (PVC-SC) stack pipe

Structural adequacy	-	not applicable
Integrity	-	No failure at 241 minutes
Insulation	-	228 minutes

This report details methods of construction, the test conditions and the results obtained when the specific element of construction described herein was tested following the procedure outlined in this standard. Any significant variation with respect to size, constructional details, loads, stresses, edge or end conditions, other than those allowed under the field of direct application in the relevant test method, is not covered by this report.

Because of the nature of fire resistance testing and the consequent difficulty in quantifying the uncertainty of measurement of fire resistance, it is not possible to provide a stated degree of accuracy of the result.

## 9 Fire-resistance level (FRL)

For the purpose of building regulations in Australia, the FRL's of the test specimens were as follows:

Penetration # 1 -	-/240/180	Penetration # 4 -	-/240/240
Penetration # 2 -	-/240/240	Penetration # 5 -	-/240/180
Penetration # 3-	-/240/240		

For the purposes of AS 1530.4-2014 the results of these fire tests may be used to directly assess fire hazard, but it should be noted that a single test method will not provide a full assessment of fire hazard under all fire conditions.

## 10 Field of direct application of test results

The results of the fire test contained in this test report are directly applicable, without reference to the testing authority, to similar constructions where one or more changes listed in Clause 10.11 of AS 1530.4-2014, have been made provided no individual component is removed or reduced.

## 11 Tested by

Chris Wojcik  
Testing Officer

# Appendices

## Appendix A – Measurement location

Measurement Location		
Group location	T/C Position	T/C designation
Specimen		
Penetration 1 – Combat Clean 100 (CC-100) cast-in collar protecting a nominal 110-mm Iplex Polyvinyl Chloride (PVC-SC) stack pipe incorporating a coupling inside the collar	On grout, 25-mm from the pipe	S1
	On grout, 25-mm from the pipe	S2
	On pipe – 25-mm from grout	S3
	On pipe – 25-mm from grout	S4
Penetration 2 – Combat Clean 40 (CC-40) cast-in collar protecting a nominal 43-mm Iplex Polyvinyl Chloride (PVC) stack pipe	On grout, 25-mm from the pipe	S5
	On grout, 25-mm from the pipe	S6
	On pipe – 25-mm from grout	S7
	On pipe – 25-mm from grout	S8
Penetration 3 – Combat Clean 50 (CC-50) cast-in collar protecting a nominal 56-mm Iplex Polyvinyl Chloride (PVC) stack pipe	On grout, 25-mm from the pipe	S9
	On grout, 25-mm from the pipe	S10
	On pipe – 25-mm from grout	S11
	On pipe – 25-mm from grout	S12
Penetration 4 – Combat Clean 50 (CC-50) cast-in collar protecting a nominal 56-mm Iplex Polyvinyl Chloride (PVC) stack pipe incorporating a fitting inside the collar	On grout, 25-mm from the pipe	S13
	On grout, 25-mm from the pipe	S14
	On pipe – 25-mm from grout	S15
	On pipe – 25-mm from grout	S16
Penetration 5 – Combat Clean 100 (CC-100) cast-in collar protecting a nominal 110-mm Iplex Polyvinyl Chloride (PVC-SC) stack pipe	On grout, 25-mm from the pipe	S17
	On grout, 25-mm from the pipe	S18
	On pipe – 25-mm from grout	S19
	On pipe – 25-mm from grout	S20

Appendix B – Photographs



PHOTOGRAPH 1 – EXPOSED FACE OF SPECIMENS PRIOR TO TESTING



PHOTOGRAPH 2 – UNEXPOSED FACE OF SPECIMENS PRIOR TO TESTING





**PHOTOGRAPH 3 – SPECIMENS AFTER 60 MINUTES OF TESTING**



**PHOTOGRAPH 4 – SPECIMENS AFTER 120 MINUTES OF TESTING**





**PHOTOGRAPH 5 – SPECIMENS AFTER 180 MINUTES OF TESTING**



**PHOTOGRAPH 6 – UNEXPOSED FACED OF SPECIMEN AT CONCLUSION OF TESTING**



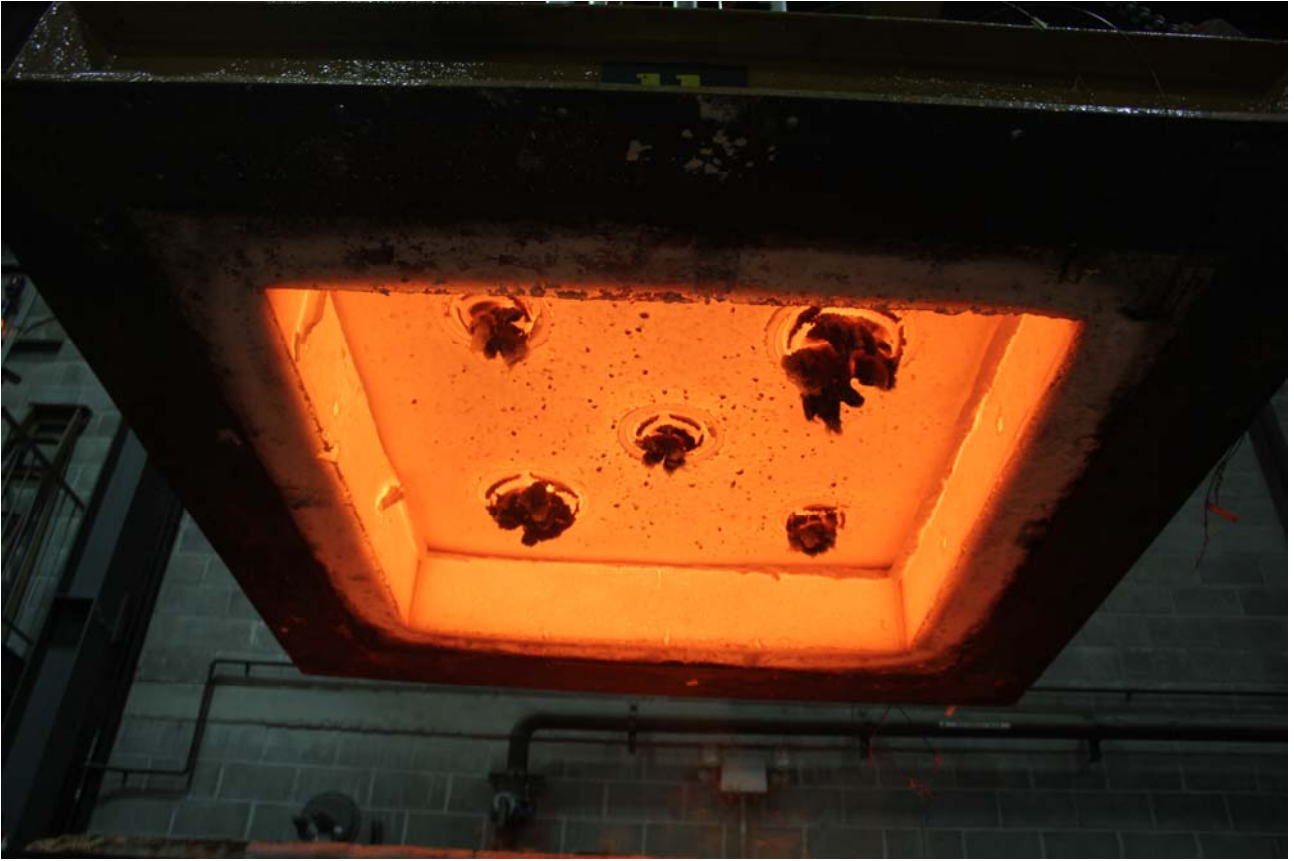

**PHOTOGRAPH 7 – EXPOSED FACE OF SPECIMENS AT CONCLUSION OF TESTING**

## Appendix C – Furnace Temperature

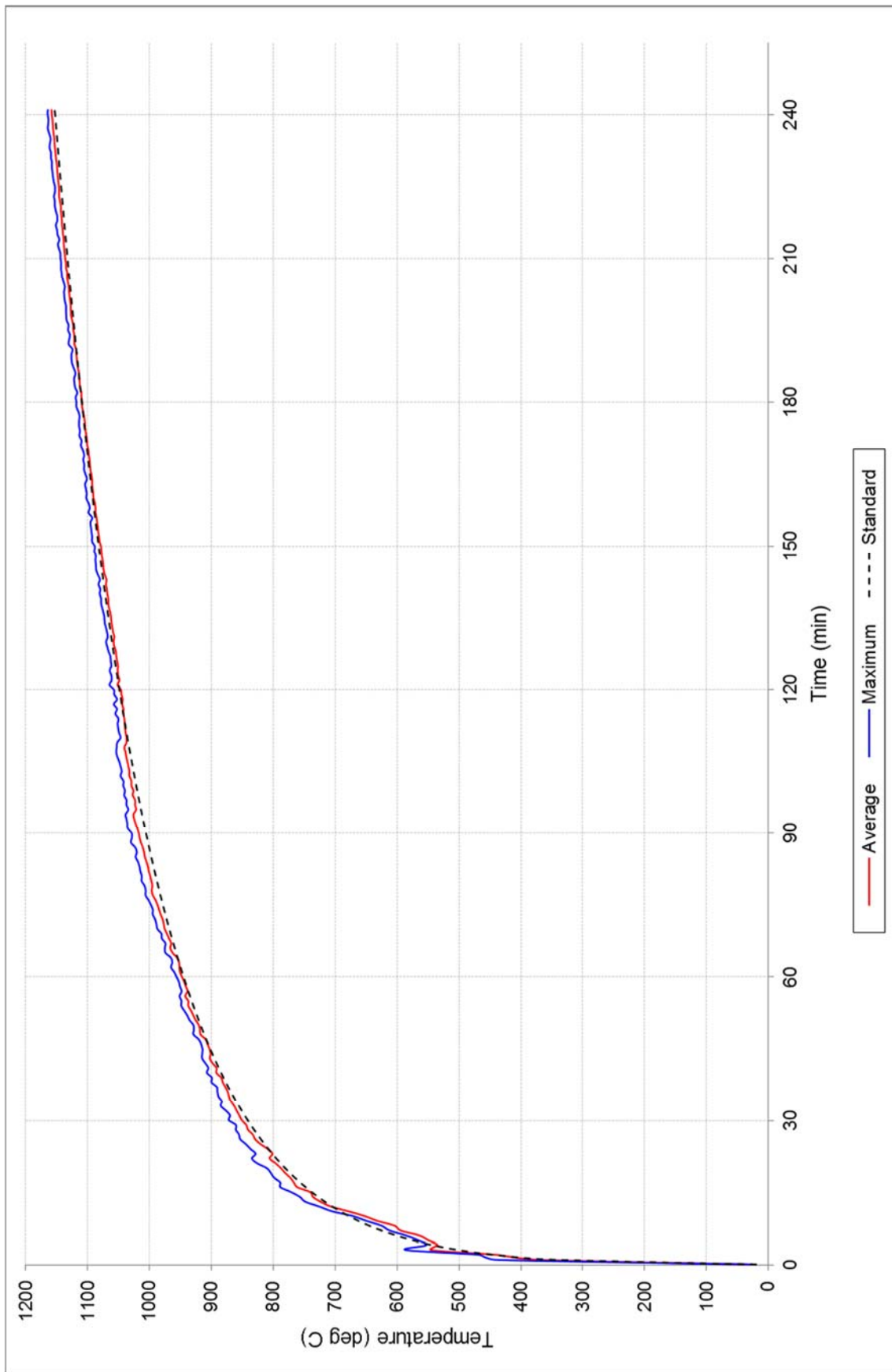

FIGURE 1 – FURNACE TEMPERATURE

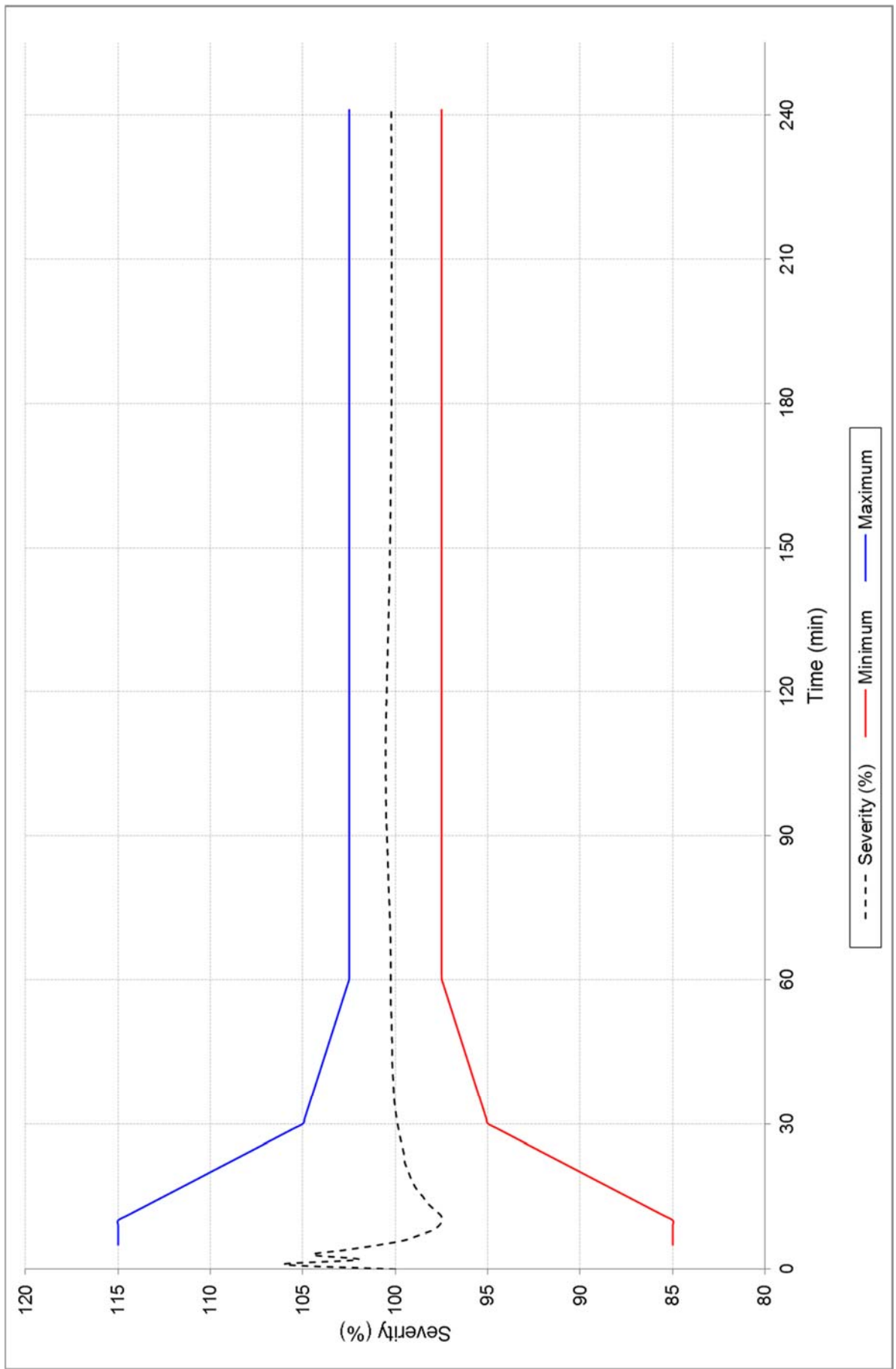

FIGURE 2 – FURNACE SEVERITY

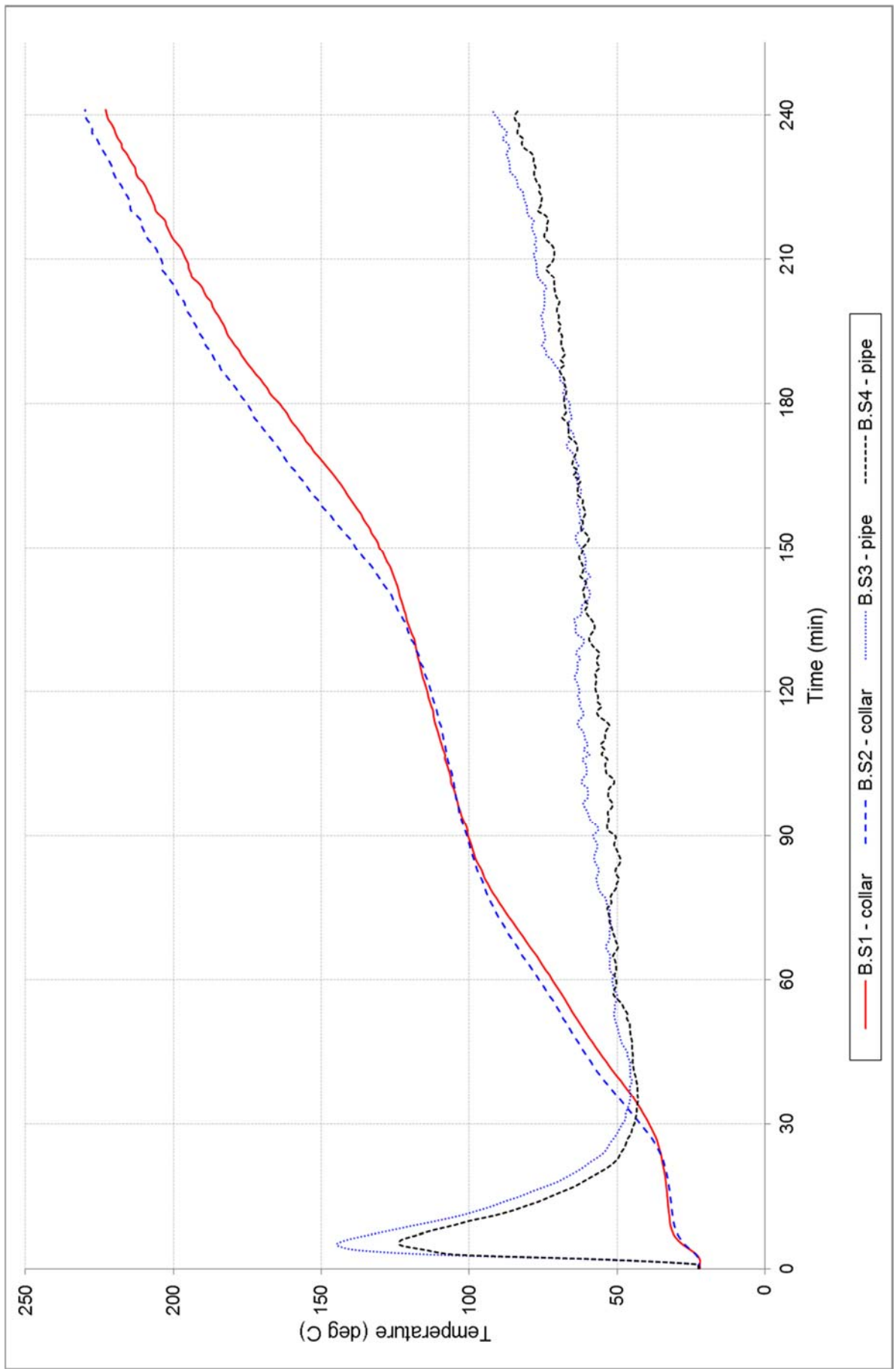

FIGURE 3 – SPECIMEN TEMPERATURE – ASSOCIATED WITH PENETRATION # 1

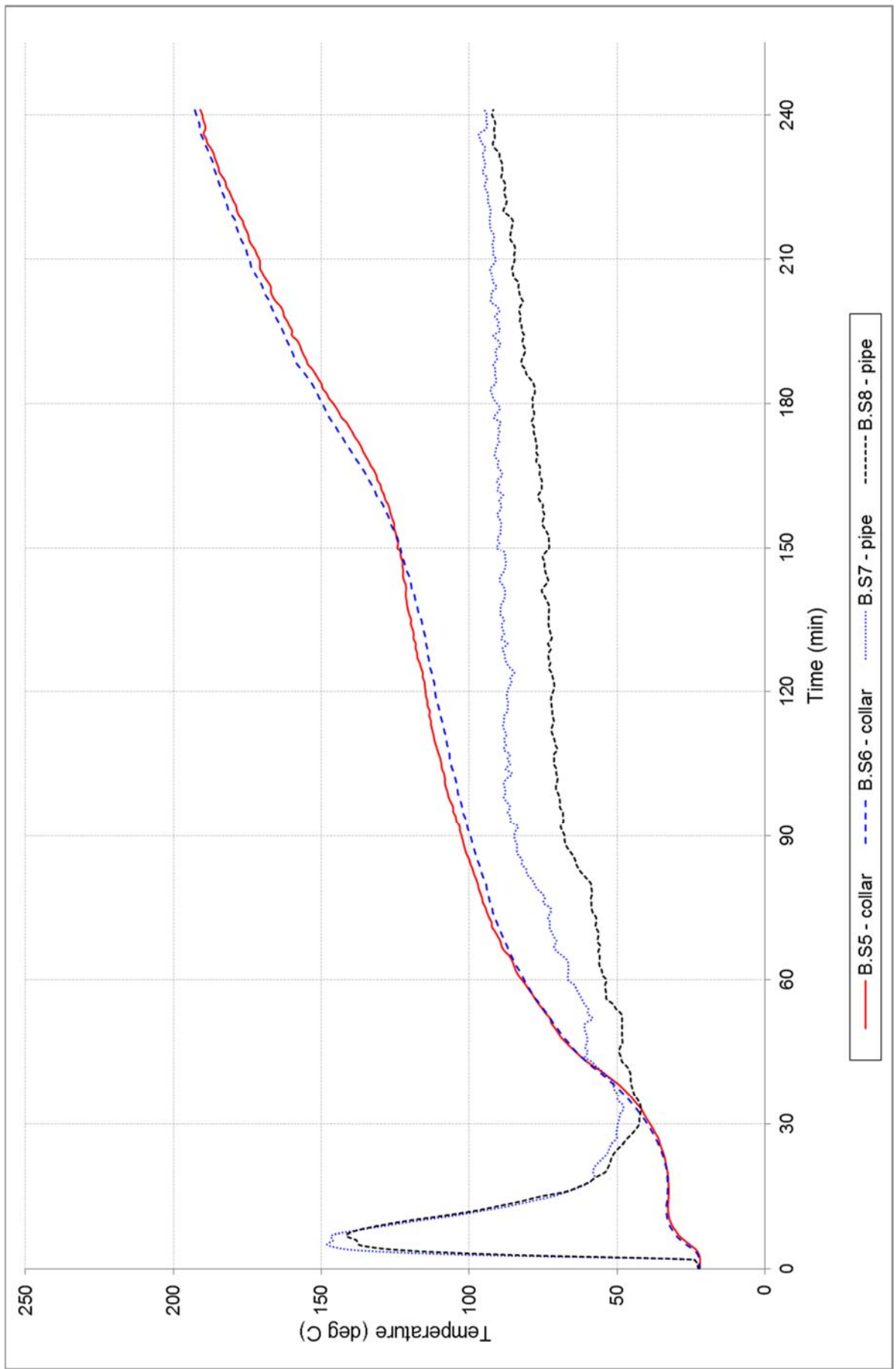

FIGURE 4 – SPECIMEN TEMPERATURE – ASSOCIATED WITH PENETRATION # 2

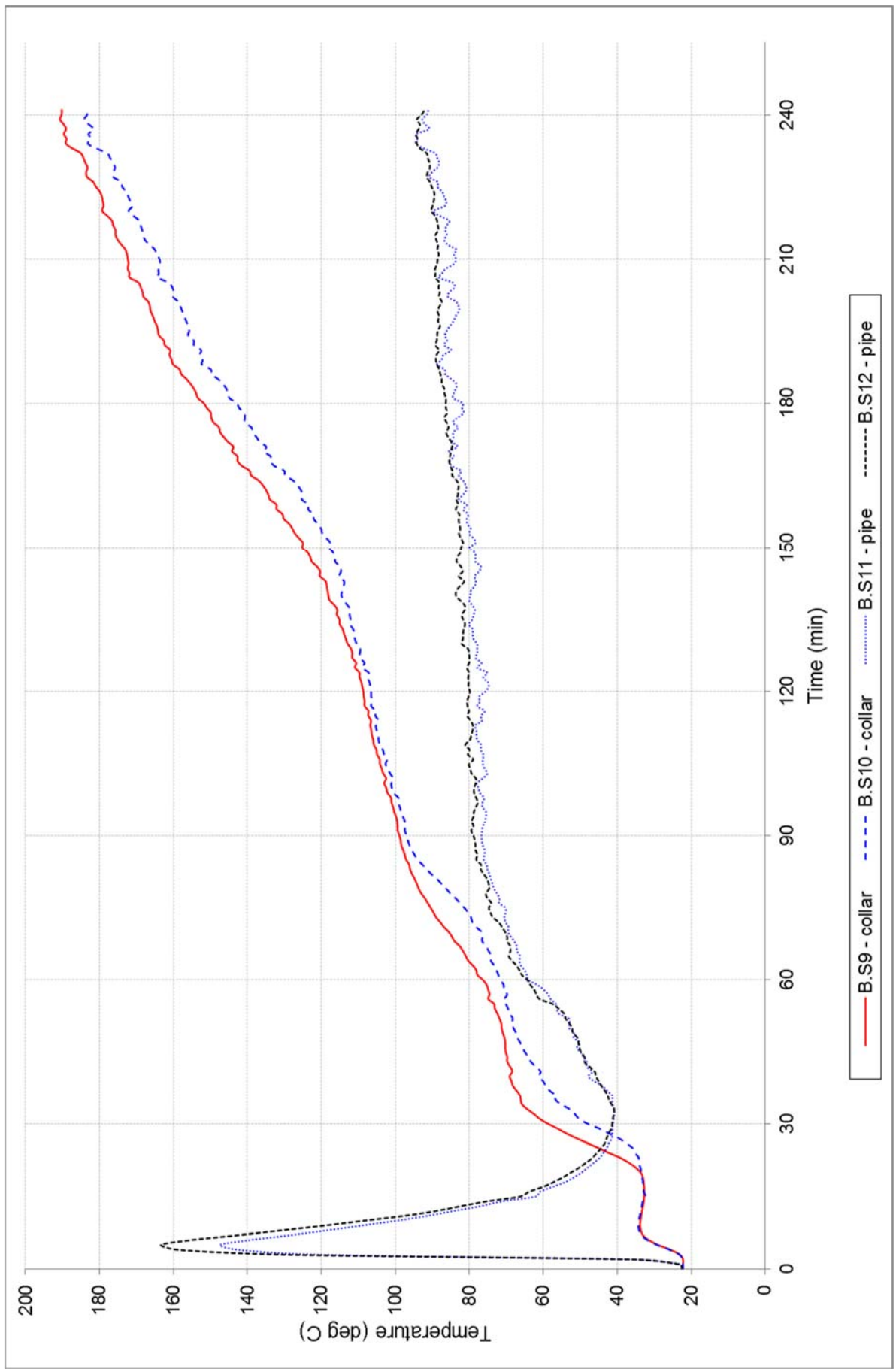

FIGURE 5 – SPECIMEN TEMPERATURE – ASSOCIATED WITH PENETRATION # 3

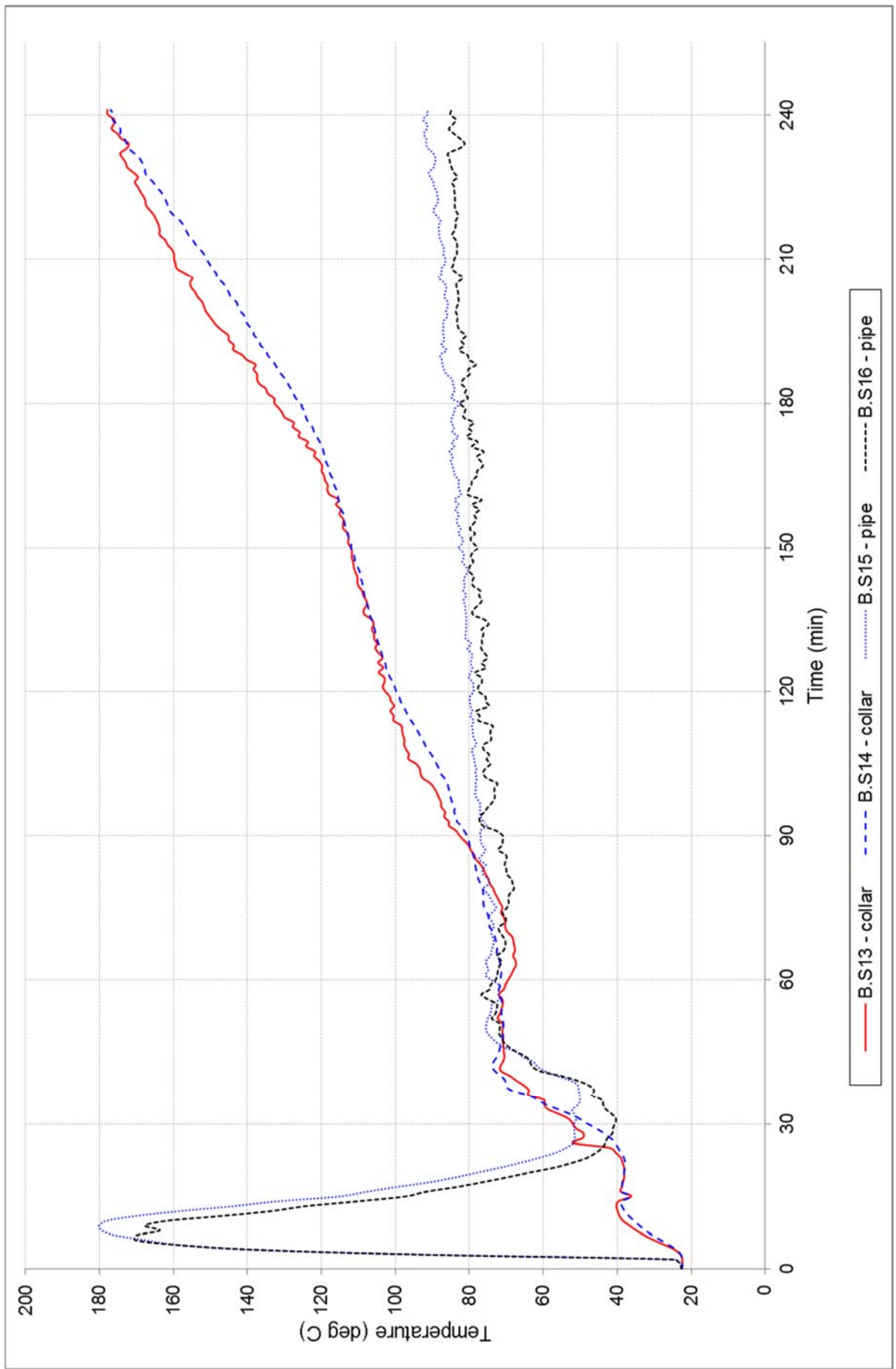

FIGURE 6 – SPECIMEN TEMPERATURE – ASSOCIATED WITH PENETRATION # 4



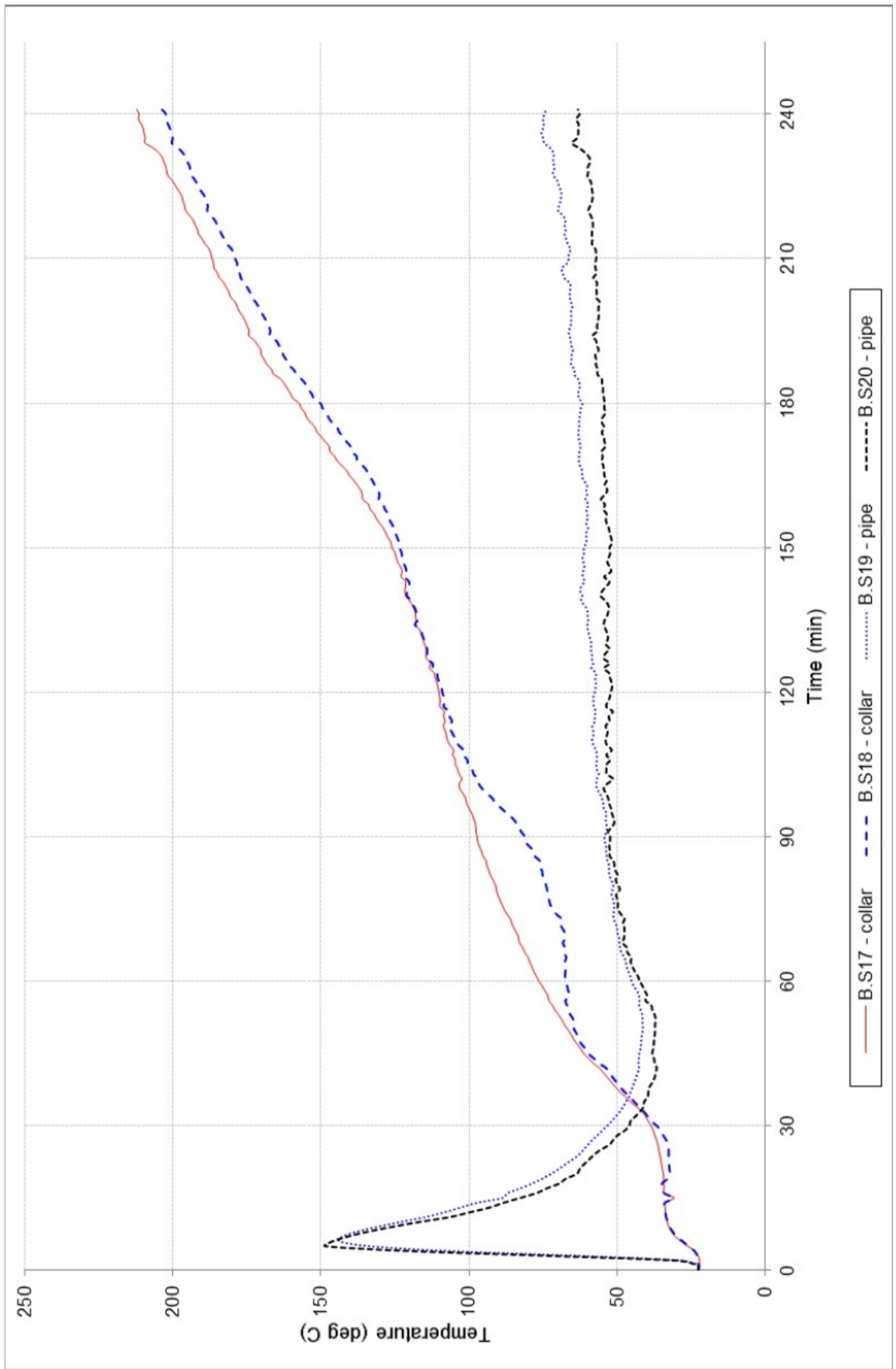
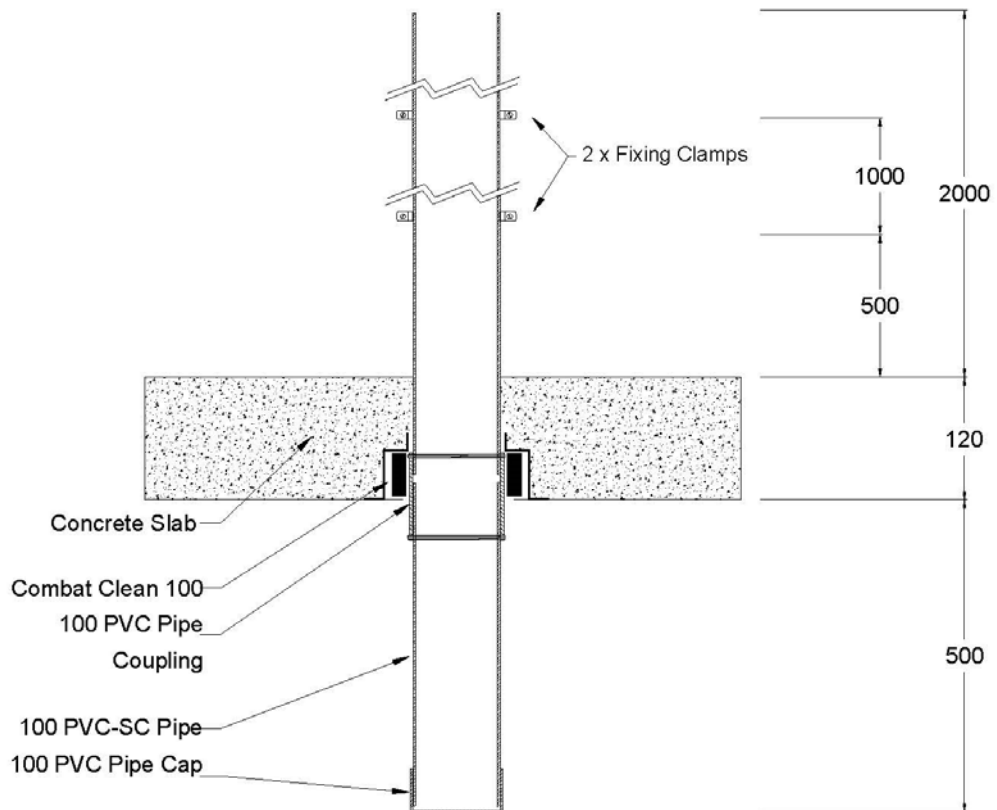

FIGURE 7 – SPECIMEN TEMPERATURE – ASSOCIATED WITH PENETRATION # 5



# Appendix D – Installation drawings

Penetration # 1  
100 PVC-SC Pipe + Fitting - Stack - Combat Clean 100  
Date: 28 Nov 2017



12/4/2017 9:30:22 PM

**DRAWING NUMBERED PENETRATION # 1 – 100 PVC-SC PIPE + FITTING – STACK – COMBAT CLEAN 100, DATED 28 NOVEMBER 2017, PROVIDED BY COMBAT COLLARS PTY LTD.**

Penetration # 2  
40 PVC Pipe - Stack - Combat Clean 40  
Date: 28 Nov 2017

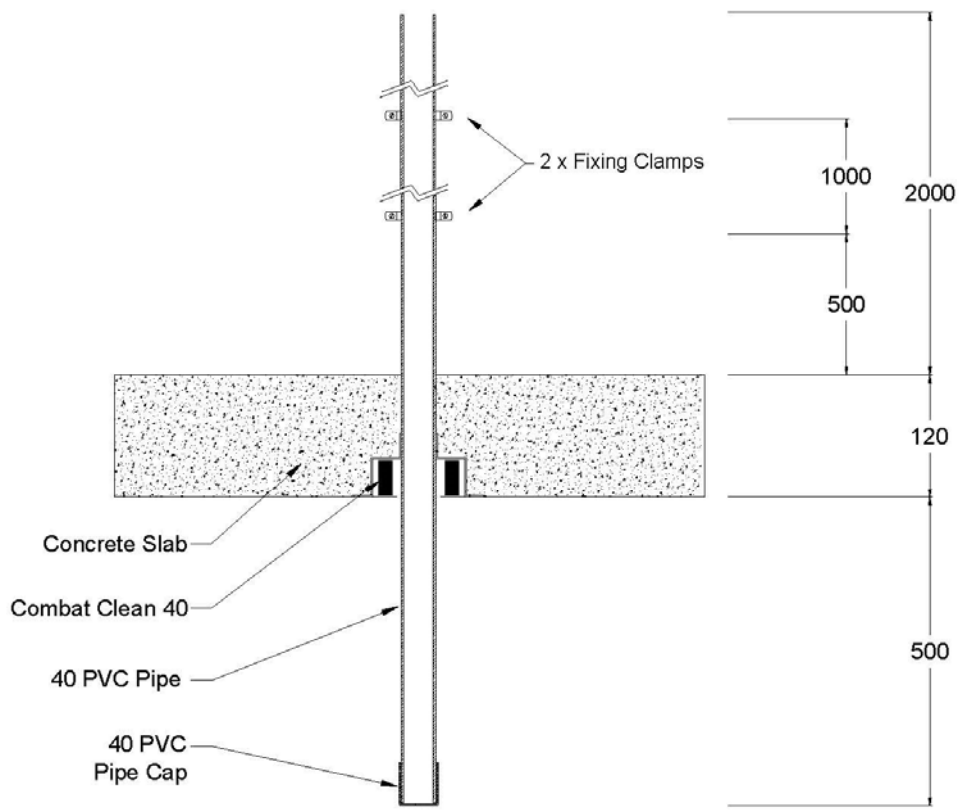

12/4/2017 9:30:23 PM

**DRAWING NUMBERED PENETRATION # 2 – 40 PVC PIPE – STACK – COMBAT CLEAN 40, DATED 28 NOVEMBER 2017, PROVIDED BY COMBAT COLLARS PTY LTD.**

Penetration # 3  
50 PVC Pipe - Stack - Combat Clean 50  
Date: 28 Nov 2017

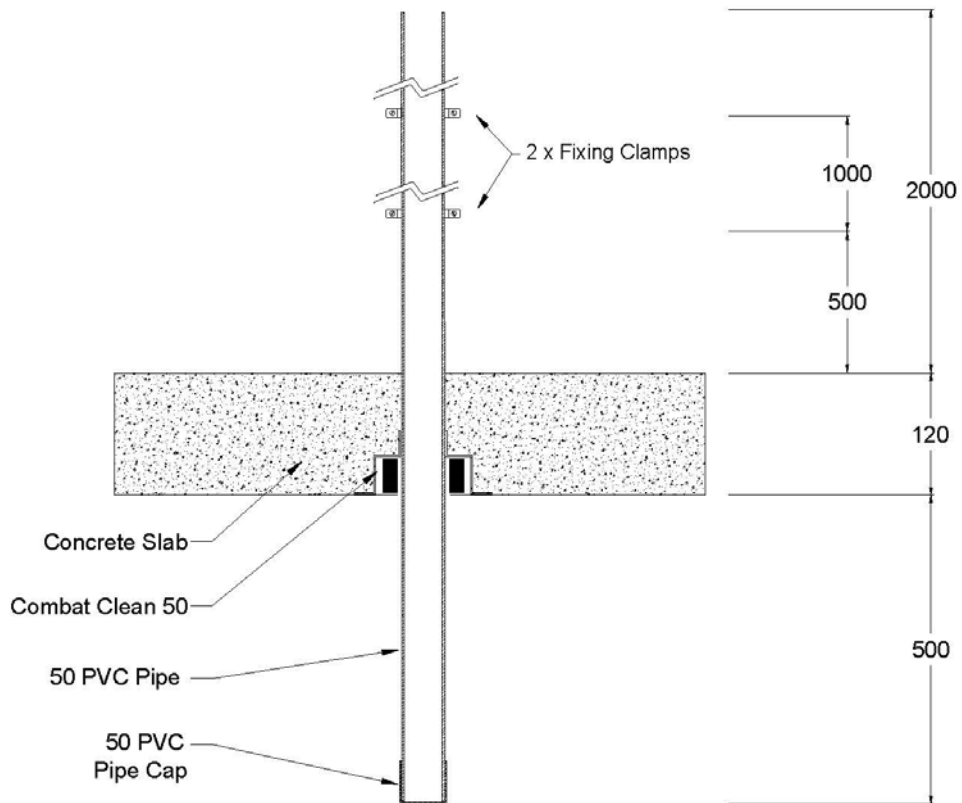

12/4/2017 9:30:24 PM

**DRAWING NUMBERED PENETRATION # 3 – 50 PVC PIPE – STACK – COMBAT CLEAN 50, DATED 28 NOVEMBER 2017, PROVIDED BY COMBAT COLLARS PTY LTD.**

Penetration # 4  
 50 PVC Pipe + Fitting - Stack - Combat Clean 50  
 Date: 28 Nov 2017

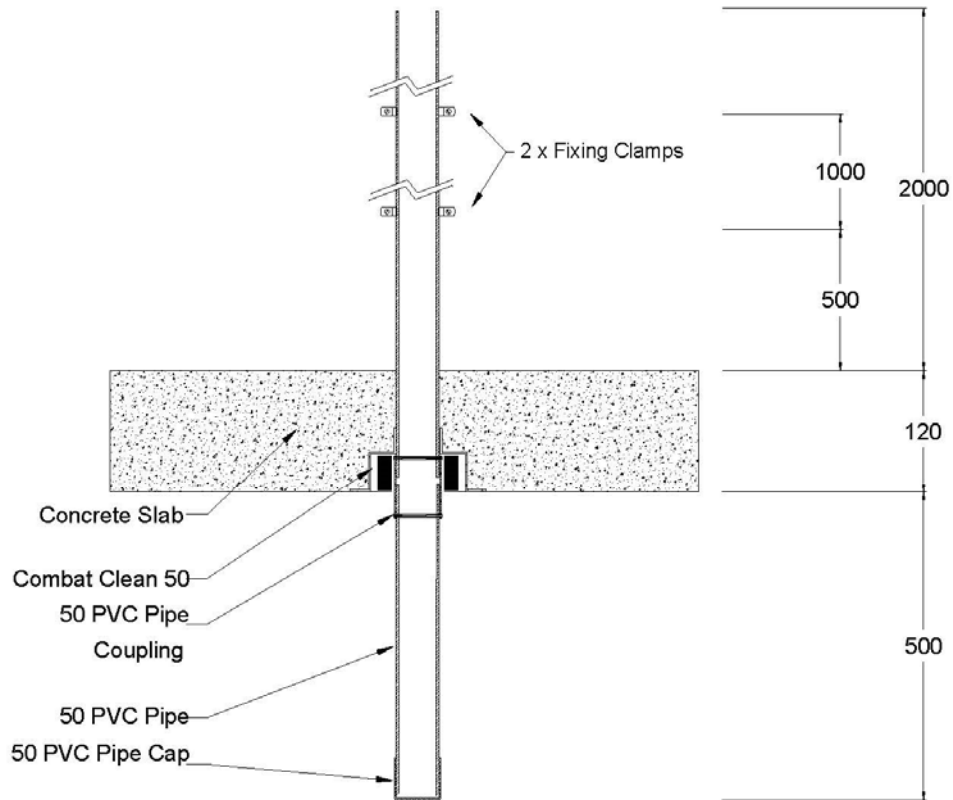

12/4/2017 9:30:25 PM

**DRAWING NUMBERED PENETRATION # 4 – 50 PVC PIPE – STACK – COMBAT CLEAN 50, DATED 28 NOVEMBER 2017, PROVIDED BY COMBAT COLLARS PTY LTD.**

Penetration # 5  
100 PVC-SC Pipe - Stack - Combat Clean 100  
Date: 28 Nov 2017

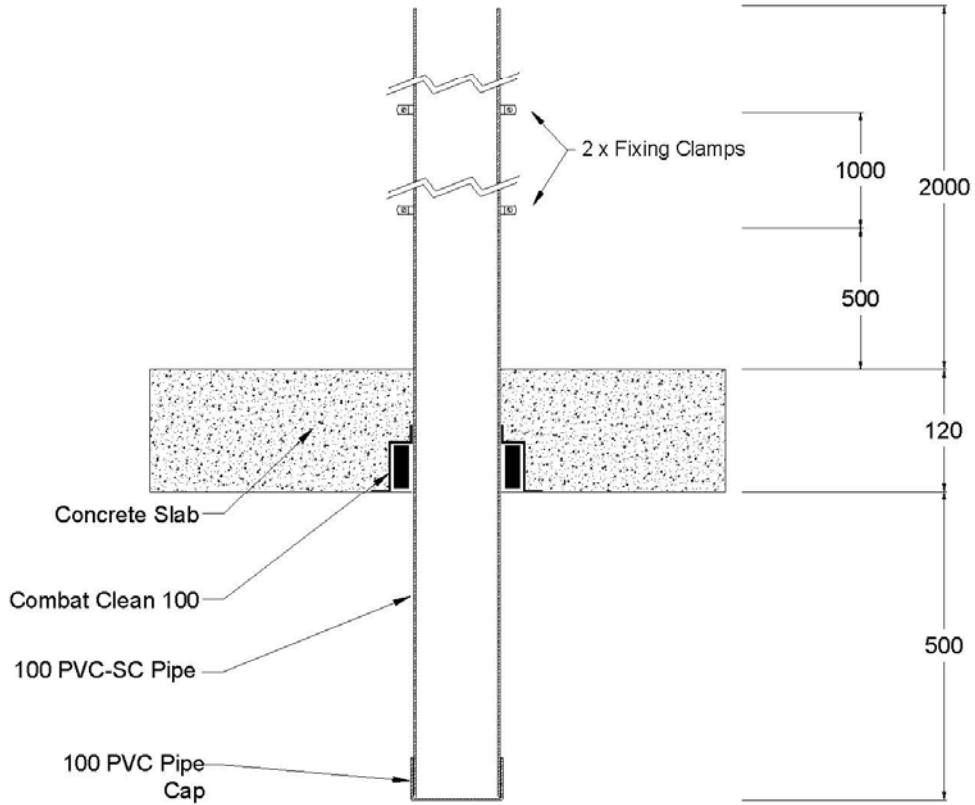

12/4/2017 9:30:26 PM

**DRAWING NUMBERED PENETRATION # 5 – 100 PVC-SC PIPE – STACK – COMBAT CLEAN 100, DATED 28 NOVEMBER 2017, PROVIDED BY COMBAT COLLARS PTY LTD.**

# Appendix E – Specimen Drawings

## COMBAT CLEAN 40 CC-40

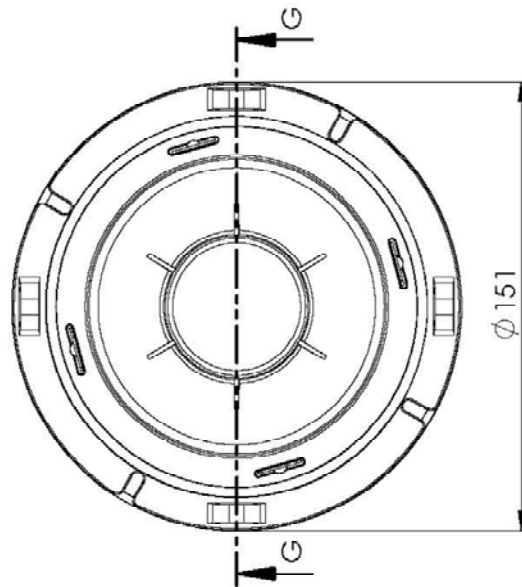
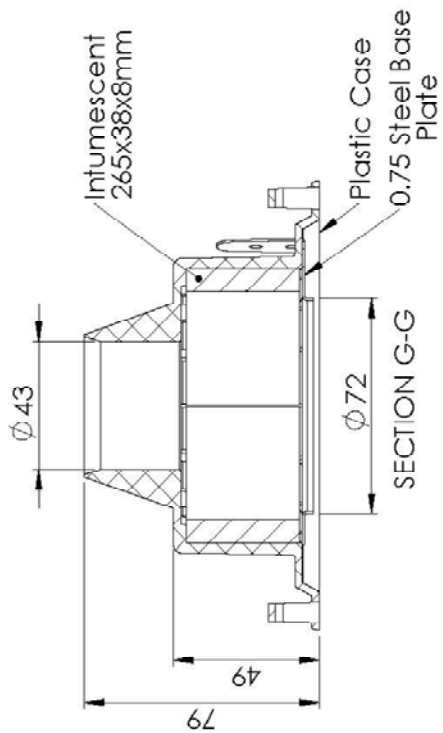
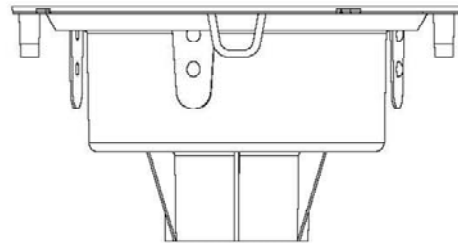
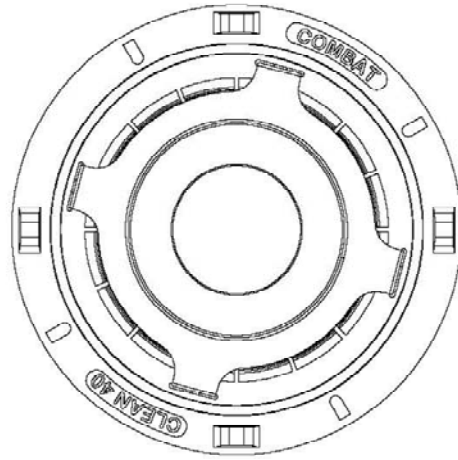
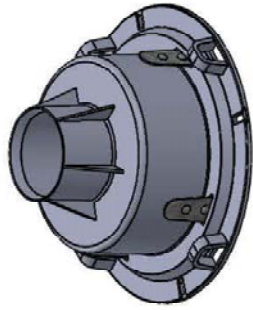

DRAWING TITLED COMBAT CLEAN 40 CC-40, UNDATED, PROVIDED BY COMBAT COLLARS PTY LTD.

# COMBAT CLEAN 50 CC-50

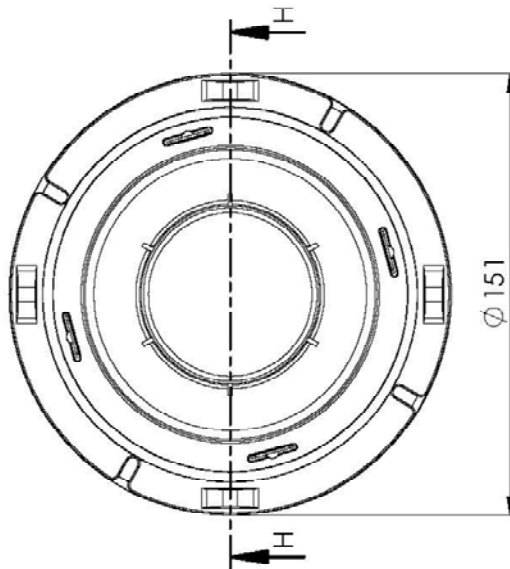
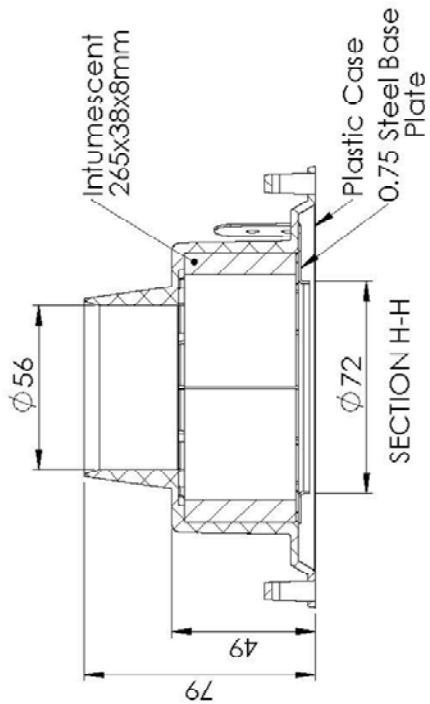
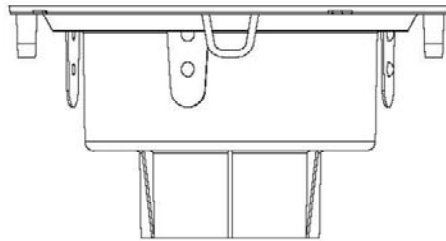
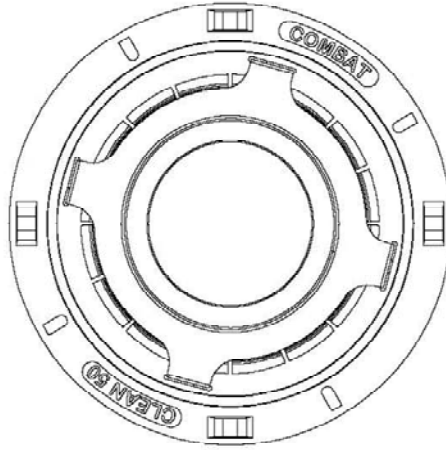
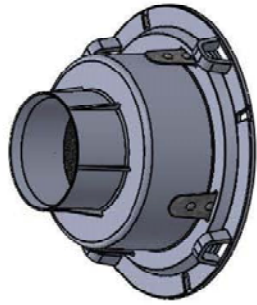

DRAWING TITLED COMBAT CLEAN 50 CC-50, UNDATED, PROVIDED BY COMBAT COLLARS PTY LTD.

# COMBAT CLEAN 100 CC-100

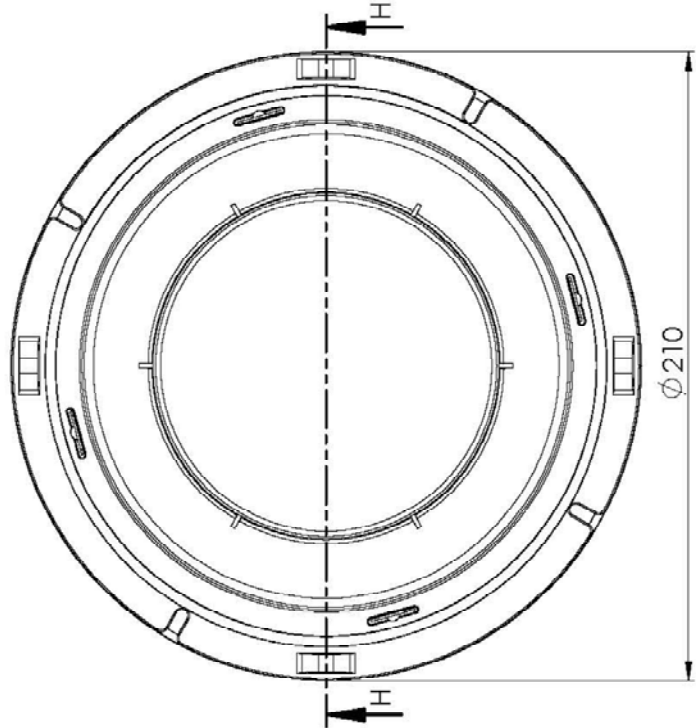
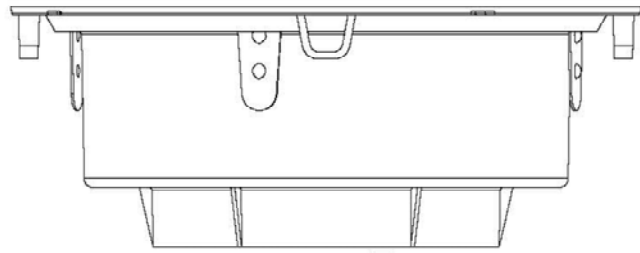
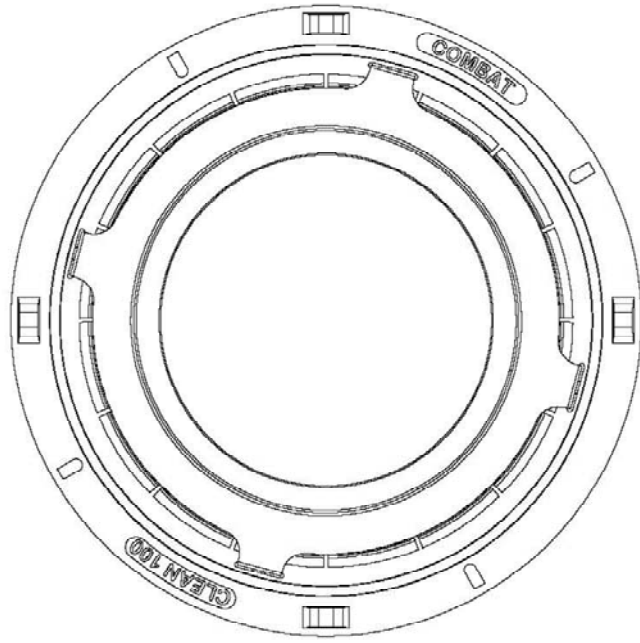
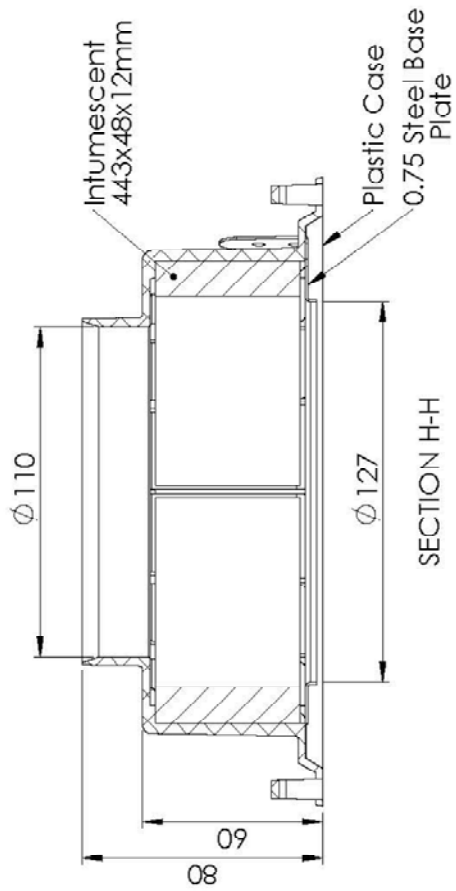
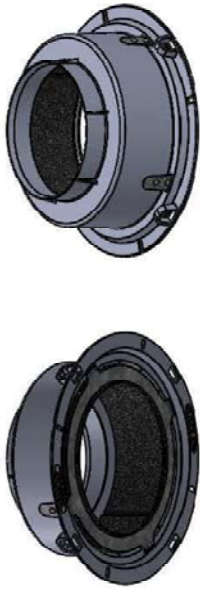

DRAWING TITLED COMBAT CLEAN 100 CC-100, UNDATED, PROVIDED BY COMBAT COLLARS PTY LTD.



# Appendix F – Certificate(s)

<b>INFRASTRUCTURE TECHNOLOGIES</b> <a href="http://www.csiro.au">www.csiro.au</a>		
14 Julius Avenue, North Ryde NSW 2113 PO Box 52, North Ryde NSW 1670, Australia T (02) 9490 5444 • ABN 41 687 119 230		
<h2>Certificate of Test</h2>		No. 3085
This is to certify that the element of construction described below was tested by CSIRO Infrastructure Technologies in accordance with Australian Standard 1530, Methods for fire tests on building materials, components and structures, Part 4 Fire-resistance tests of elements of construction, 2014 on behalf of:		
Combat Collars Pty Ltd 17 Glenn Street, Dean Park NSW 2761		
A full description of the test specimen and the complete test results are detailed in the Division's Sponsored Investigation report numbered FSP 1857.		
Product Name: Penetration 1 – Combat Clean 100 (CC-100) cast-in collar protecting a nominal 100-mm Iplex Polyvinyl Chloride (PVC-SC) stack pipe incorporating a coupling inside the collar		
Description: The Combat Clean 100 collar comprised a plastic casing with an 110-mm inner diameter, a 210-mm external diameter base flange, and 0.75-mm thick steel base plate. The 80-mm high collar casing incorporated a layer of 443-mm x 48-mm x 12-mm thick intumescent material, as shown in drawing titled Combat Clean 100 CC-100 provided by Combat Collars Pty Ltd. The penetrating service comprised a 110-mm outer diameter PVC-SC pipe with a wall thickness of 3.6-mm fitted through the collar, with a coupling located in the collar's sleeve, for a total wall thickness of 6.6-mm through the collar's sleeve. The pipe projected vertically, 2000-mm above the concrete slab and approximately 500-mm into the furnace chamber. The pipe was supported at nominally 500-mm and 1500-mm from the unexposed face of the slab by two support clamps spaced apart at nominally 1000-mm. The pipe was open at the unexposed end and capped on the exposed end with a 100-mm PVC pipe cap.		
Structural Adequacy	Integrity	Insulation
not applicable	no failure at 241 minutes	207 minutes
and therefore for the purpose of Building Regulations in Australia, achieved a fire-resistance level (FRL) of -/240/180.		
For the purposes of AS 1530.4-2014 the results of these fire tests may be used to directly assess fire hazard, but it should be recognized that a single test method will not provide a full assessment of fire hazard under all fire conditions. This certificate is provided for general information only and does not comply with regulatory requirements for evidence of compliance.		
Testing Officer:	Chris Wojcik	Date of Test: 17 October 2017
Issued on the 19 <sup>th</sup> day of March 2018 without alterations or additions.		
		
Brett Roddy Manager, Fire Testing and Assessments		
"Copyright CSIRO 2017 ©" Copying or alteration of this report without written authorisation from CSIRO is forbidden		
	This document is issued in accordance with NATA's accreditation requirements. Accreditation No. 165 – Corporate Site No. 3625 Accredited for compliance with ISO/IEC 17025 - Testing	

**COPY OF CERTIFICATE OF TEST – NO. 3085**



## Certificate of Test

No. 3086

This is to certify that the element of construction described below was tested by CSIRO Infrastructure Technologies in accordance with Australian Standard 1530, Methods for fire tests on building materials, components and structures, Part 4 Fire-resistance tests of elements of construction, 2014 on behalf of:

Combat Collars Pty Ltd  
17 Glenn Street,  
Dean Park NSW 2761

A full description of the test specimen and the complete test results are detailed in the Division's Sponsored Investigation report numbered FSP 1857.

Product Name: Penetration 2 – Combat Clean 40 (CC-40) cast-in collar protecting a nominal 40-mm Polyvinyl Chloride (PVC) stack pipe

Description: The Combat Clean 40 collar comprised a plastic casing with a 43 mm inner diameter, a 151 mm external diameter base flange, and 0.75 mm thick steel base plate. The 79-mm high collar casing incorporated a layer of 265 mm x 38 mm x 8-mm thick intumescent material, as shown in drawing titled Combat Clean 40 CC-40 provided by Combat Collars Pty Ltd. The penetrating service comprised a 43-mm outer diameter PVC pipe with a wall thickness of 2 mm fitted through the collar. The pipe projected vertically, 2000-mm above the concrete slab and approximately 500 mm into the furnace chamber. The pipe was supported at nominally 500-mm and 1500 mm from the unexposed face of the slab by two support clamps spaced apart at nominally 1000-mm. The pipe was open at the unexposed end and capped on the exposed end with a 40-mm PVC pipe cap.

Structural Adequacy	not applicable
Integrity	no failure at 241 minutes
Insulation	no failure at 241 minutes

and therefore for the purpose of Building Regulations in Australia, achieved a fire-resistance level (FRL) of -/240/240.

For the purposes of AS 1530.4-2014 the results of these fire tests may be used to directly assess fire hazard, but it should be recognized that a single test method will not provide a full assessment of fire hazard under all fire conditions. This certificate is provided for general information only and does not comply with regulatory requirements for evidence of compliance.

Testing Officer: Chris Wojcik

Date of Test: 17 October 2017

Issued on the 19<sup>th</sup> day of March 2018 without alterations or additions.

Brett Roddy  
Manager, Fire Testing and Assessments

“Copyright CSIRO 2017 ©”  
Copying or alteration of this report without written authorisation from CSIRO is forbidden



This document is issued in accordance with NATA's accreditation requirements.  
Accreditation No. 165 – Corporate Site No. 3625  
Accredited for compliance with ISO/IEC 17025 - Testing



## Certificate of Test

No. 3087

This is to certify that the element of construction described below was tested by CSIRO Infrastructure Technologies in accordance with Australian Standard 1530, Methods for fire tests on building materials, components and structures, Part 4 Fire-resistance tests of elements of construction, 2014 on behalf of:

Combat Collars Pty Ltd  
17 Glenn Street,  
Dean Park NSW 2761

A full description of the test specimen and the complete test results are detailed in the Division's Sponsored Investigation report numbered FSP 1857.

Product Name: Penetration 3 – Combat Clean 50 (CC-50) cast-in collar protecting a nominal 50-mm Iplex Polyvinyl Chloride (PVC) stack pipe

Description: The Combat Clean 50 collar comprised a plastic casing with a 56 mm inner diameter, a 151 mm external diameter base flange, and 0.75 mm thick steel base plate. The 79-mm high collar casing incorporated a layer of 265 mm x 38 mm x 8-mm thick intumescent material, as shown in drawing titled Combat Clean 50 CC-50 by Combat Collars Pty Ltd. The penetrating service comprised a 56-mm outer diameter PVC pipe with a wall thickness of 2.3 mm fitted through the collar. The pipe projected vertically, 2000-mm above the concrete slab and approximately 500 mm into the furnace chamber. The pipe was supported at nominally 500-mm and 1500 mm from the unexposed face of the slab by two support clamps spaced apart at nominally 1000-mm. The pipe was open at the unexposed end and capped on the exposed end with a 56-mm PVC pipe cap.

Structural Adequacy	not applicable
Integrity	no failure at 241 minutes
Insulation	no failure at 241 minutes

and therefore for the purpose of Building Regulations in Australia, achieved a fire-resistance level (FRL) of -/240/240.

For the purposes of AS 1530.4-2014 the results of these fire tests may be used to directly assess fire hazard, but it should be recognized that a single test method will not provide a full assessment of fire hazard under all fire conditions. This certificate is provided for general information only and does not comply with regulatory requirements for evidence of compliance.

Testing Officer: Chris Wojcik

Date of Test: 17 October 2017

Issued on the 19<sup>th</sup> day of March 2018 without alterations or additions.

Brett Roddy  
Manager, Fire Testing and Assessments

“Copyright CSIRO 2017 ©”  
Copying or alteration of this report without written authorisation from CSIRO is forbidden



This document is issued in accordance with NATA's accreditation requirements.  
Accreditation No. 165 – Corporate Site No. 3625  
Accredited for compliance with ISO/IEC 17025 - Testing



## Certificate of Test

No. 3088

This is to certify that the element of construction described below was tested by CSIRO Infrastructure Technologies in accordance with Australian Standard 1530, Methods for fire tests on building materials, components and structures, Part 4 Fire-resistance tests of elements of construction, 2014 on behalf of:

Combat Collars Pty Ltd  
17 Glenn Street,  
Dean Park NSW 2761

A full description of the test specimen and the complete test results are detailed in the Division's Sponsored Investigation report numbered FSP 1857.

Product Name: Penetration 4 – Combat Clean 50 (CC-50) cast-in collar protecting a nominal 50-mm Iplex Polyvinyl Chloride (PVC) stack pipe incorporating a fitting inside the collar

Description: The Combat Clean 50 collar comprised a plastic casing with a 56 mm inner diameter, a 151 mm external diameter base flange, and 0.75 mm thick steel base plate. The 79-mm high collar casing incorporated a layer of 265 mm x 38 mm x 8-mm thick intumescent material, as shown in drawing titled Combat Clean 50 CC-50 by Combat Collars Pty Ltd. The penetrating service comprised a 56-mm outer diameter PVC pipe with a wall thickness of 2.3 mm fitted through the collar, with a coupling located in the collar's sleeve, for a total wall thickness of 4.6 mm through the collar's sleeve. The pipe projected vertically, 2000-mm above the concrete slab and approximately 500 mm into the furnace chamber. The pipe was supported at nominally 500-mm and 1500 mm from the unexposed face of the slab by two support clamps spaced apart at nominally 1000-mm. The pipe was open at the unexposed end and capped on the exposed end with a 56-mm PVC pipe cap.

Structural Adequacy	not applicable
Integrity	no failure at 241 minutes
Insulation	no failure at 241 minutes

and therefore for the purpose of Building Regulations in Australia, achieved a fire-resistance level (FRL) of -/240/240.

For the purposes of AS 1530.4-2014 the results of these fire tests may be used to directly assess fire hazard, but it should be recognized that a single test method will not provide a full assessment of fire hazard under all fire conditions. This certificate is provided for general information only and does not comply with regulatory requirements for evidence of compliance.

Testing Officer: Chris Wojcik Date of Test: 17 October 2017

Issued on the 19<sup>th</sup> day of March 2018 without alterations or additions.

Brett Roddy  
Manager, Fire Testing and Assessments

“Copyright CSIRO 2017 ©”  
Copying or alteration of this report without written authorisation from CSIRO is forbidden



This document is issued in accordance with NATA's accreditation requirements.  
Accreditation No. 165 – Corporate Site No. 3625  
Accredited for compliance with ISO/IEC 17025 - Testing





## Certificate of Test

No. 3089

This is to certify that the element of construction described below was tested by CSIRO Infrastructure Technologies in accordance with Australian Standard 1530, Methods for fire tests on building materials, components and structures, Part 4 Fire-resistance tests of elements of construction, 2014 on behalf of:

Combat Collars Pty Ltd  
17 Glenn Street,  
Dean Park NSW 2761

A full description of the test specimen and the complete test results are detailed in the Division's Sponsored Investigation report numbered FSP 1857.

Product Name: Penetration 5 – Combat Clean 100 (CC-100) cast-in collar protecting a nominal 100-mm Iplex Polyvinyl Chloride (PVC-SC) stack pipe

Description: The Combat Clean 100 collar comprised a plastic casing with a 110 mm inner diameter, a 210 mm external diameter base flange, and 0.75 mm thick steel base plate. The 80-mm high collar casing incorporated a layer of 443 mm x 48 mm x 12-mm thick intumescent material, as shown in drawing titled Combat Clean 100 CC-100 provided by Combat Collars Pty Ltd. The penetrating service comprised a 110-mm outer diameter PVC-SC pipe with a wall thickness of 3.3 mm fitted through the collar. The pipe projected vertically, 2000-mm above the concrete slab and approximately 500 mm into the furnace chamber. The pipe was supported at nominally 500-mm and 1500 mm from the unexposed face of the slab by two support clamps spaced apart at nominally 1000-mm. The pipe was open at the unexposed end and capped on the exposed end with a 110-mm PVC pipe cap.

Structural Adequacy	not applicable
Integrity	no failure at 241 minutes
Insulation	228 minutes

and therefore for the purpose of Building Regulations in Australia, achieved a fire-resistance level (FRL) of -/240/180.

For the purposes of AS 1530.4-2014 the results of these fire tests may be used to directly assess fire hazard, but it should be recognized that a single test method will not provide a full assessment of fire hazard under all fire conditions. This certificate is provided for general information only and does not comply with regulatory requirements for evidence of compliance.

Testing Officer: Chris Wojcik

Date of Test: 17 October 2017

Issued on the 19<sup>th</sup> day of March 2018 without alterations or additions.

Brett Roddy  
Manager, Fire Testing and Assessments

"Copyright CSIRO 2017 ©"  
Copying or alteration of this report without written authorisation from CSIRO is forbidden



This document is issued in accordance with NATA's accreditation requirements.  
Accreditation No. 165 – Corporate Site No. 3625  
Accredited for compliance with ISO/IEC 17025 - Testing

# References

The following informative documents are referred to in this Report:

- AS 1530.4-2014      Methods for fire tests on building materials, components and structures Part 4: Fire-resistance tests of elements of building construction.
- AS 4072.1-2005      Components for the protection of openings in fire-resistant separating elements. Part 1: Service penetrations and control joints.

-----end of report-----

#### CONTACT US

**t** 1300 363 400  
+61 3 9545 2176  
**e** [enquiries@csiro.au](mailto:enquiries@csiro.au)  
**w** [www.csiro.au](http://www.csiro.au)

#### YOUR CSIRO

Australia is founding its future on science and innovation. Its national science agency, CSIRO, is a powerhouse of ideas, technologies and skills for building prosperity, growth, health and sustainability. It serves governments, industries, business and communities across the nation.

#### FOR FURTHER INFORMATION

##### **Infrastructure Technologies**

Brett Roddy  
Team Leader, Fire Testing and Assessments

**t** +61 2 94905449

**e** [brett.rodny@csiro.au](mailto:brett.rodny@csiro.au)

**w** [www.csiro.au/Organisation-Structure/Divisions/CMSE/Infrastructure-Technologies/Fire-safety.aspx](http://www.csiro.au/Organisation-Structure/Divisions/CMSE/Infrastructure-Technologies/Fire-safety.aspx)